

Fiber-optic Recirculating Loop

--A key equipment to evaluate performance of long and ultra-long distance

optical fiber communication systems

There are great interests in studying long distance optical fiber communications for both transoceanic and terrestrial communication applications. However, it is very expensive to characterize such long transmission systems, even in laboratories. A recirculating loop would provide a very useful and flexible way to emulate such systems of multi-thousand kilometers.

In our optical fiber recirculating loop with model number **OEFRL-100**, a data-encoded optical pulse stream is sent into a fiber loop of typically 100km to 400km and circulated any number from a couple of loops to up to 100 loops. After a given number of loops, optical signal is coupled out and analyzed. Several transmission parameters, such as eye diagrams, Q-factor, pulse shape, spectrum, chirp or bit error rate (BER), can be measured to see how the signal degrades due to fiber dispersion, loss and nonlinearity, or how the signal improves with dispersion compensation, dispersion management, or in-line transmission control. For example, the side-by-side comparison of two transmission fiber types or amplifier designs for long-haul transmission systems is more easily and economically made in a loop measurement than in a straight-line testbed given the equipment involved.



System Configuration Diagram:

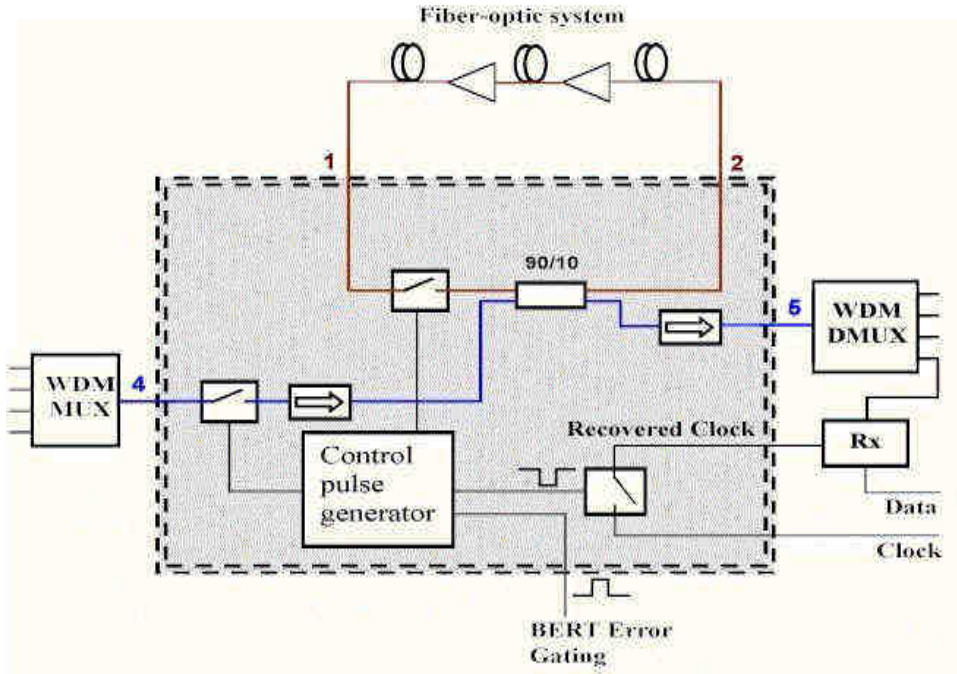

System Features:

Parameter	Description	
Wavelength band	1528-1600 nm (each direction, any optical port)	
Returning loss any port	-27dB ORL (1528-1600 nm)	
Max optical power	23 dBm (average)	
PDL	< 0.2 dB any two ports required to operate in recirculating loop mode	
MPI	< -42 dB relative	
Insertion loss	port 1 – port 2	5 dB max
	port 1 – port 5	14.5 dB max
Delay time	< 2 μ sec (10% ~ 90% switch)	
	< 3 μ sec (settling time)	
Polarization Dispersion	< 0.1 ps ports 1-2	

Note: All specifications are subject to change without notice.

Typical Eye Diagrams for an OC-48 NRZ Transmission Experiment using Recirculating Loop (SMF-28)

● 75 Kilometers

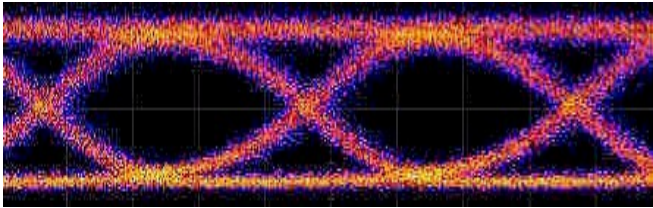

● 600 Kilometers

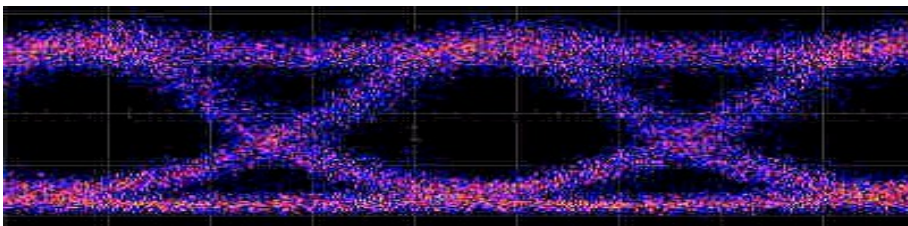

● 1500 Kilometers

